

## MARINE GENERATORS

# 25 GT/GTC

Three-Phase

### General data

<b>Maximum power*</b>	19.4 kW (24.3 kVA)	<b>Voltage</b>	400/230 V
<b>Prime Power**</b>	17.7 kW	<b>Amperage</b>	35.1 A
<b>Frequency</b>	50 Hz	<b>Phases</b>	3

### Dimensions and weights

<b>Total length without canopy</b>	1140 mm	<b>Total length with canopy</b>	1310 mm
<b>Total width without canopy</b>	610 mm	<b>Total width with canopy</b>	610 mm
<b>Total height without canopy</b>	662 mm	<b>Total height with canopy</b>	698 mm
<b>Dry weight without canopy</b>	351 Kg	<b>Dry weight with canopy</b>	412 Kg

### Engine

<b>Base engine manufacturer</b>	Mitsubishi	<b>Diameter</b>	88 mm (3.46 in)
<b>Model</b>	MINI-63 GENSET	<b>Stroke</b>	103 mm (4.06 in)
<b>Type</b>	Diesel, 4 stroke	<b>Compression ratio</b>	22:1
<b>Engine RPM</b>	1500	<b>Injection system</b>	Mechanical and direct
<b>Number of cylinders</b>	4	<b>Intake system</b>	Naturally aspirated
<b>Total displacement</b>	2505 cc	<b>SAE Flywheel housing</b>	SAE 4
<b>Oil</b>	SAE 15W40	<b>Coolant capacity</b>	9.5 L (2.51 gal)
<b>Oil capacity</b>	6.5 L (1.72 gal)	<b>Flywheel</b>	SAE 7 1/2
<b>Power</b>	21.5 kW (29.24 CV)	<b>Coolant flow rate</b>	52 l/min (13.74 gal/m)
<b>Salt water flow rate</b>	38 l/min (10.04 gal/m)	<b>Intake air flow rate</b>	1.65 m <sup>3</sup> /m
<b>Exhaust type</b>	Wet exhaust elbow	<b>V-Belt Protection</b>	Optional

Rating conditions according to ISO 3046 (100 kPa barometric pressure, 30 % relative humidity abd 25 °C (77 ° F))

\* Maximum output power: maximum power supplied by the genset at full load

\*\* Prime Power: rated power according to ISO 3046 and ISO 8528-1. 10 % overload capacity one hour in twelve hours.

Fuel system details

1 kW □ 1,36 CV 1 kW □ 1,36 HP (metric) 1 kW □ 1,36 CH

45461 - 6/24

## Fuel system details

Consumption 25%	2.4 l/h (0.63 gal)	Fuel type	Diesel
Consumption 50%	3.5 l/h (0.92 gal)	Fuel standards	Fueloil diesel ASTM
Consumption 75%	4.75 l/h (1.25 gal)	Injection pump type	In line
Consumption 100%	6.4 l/h (1.69 gal)	Governor type	Mechanical

## Electrical system

Battery voltage	12 V	Stop solenoid type	ETR
Starter motor	2 kW	Alternator	50 A
Earth isolated	Optional	IP 65 box kit	Optional
SCO 11 double panel	Optional	Current transformers	Optional

## Installation details

Exhaust hose inner diameter	60 mm (2.36 in)	Maximum fuel lift height	0.6 m (1.97 ft)
Sea water hose inner diameter	32 mm (1.26 in)	Maximum raw water lift height	3 m (118.11 in)
Fuel feeding hose inner diameter	8 mm (0.31 in)	Maximum sea water temperature	32 ° (89.6 °F)
Fuel return hose inner diameter	- (- in)	Maximum installation angle***	15 °
Minimum battery capacity	12 V 95 Ah		

## Alternator details

Brand	Sincro	Cos Phi	0,8
Model	SK160LA	Tropicalized	Yes
Regulator type	BL4	Excitation system	BRUSHLESS
Number of poles	4	Voltage regulation accuracy**	1%
Isolation type*	H	Standards	EN 60034-1, IEC 60034-1, ISO 8528-3
IP protection	23	Alternator type	SÍNCRONO

## Standard equipment

4 m electrical wiring extension	SCO 5 control panel
Oil extraction pump	Owner's and alternator manual
Rigid bed	Packaging
Silentblocks	

## Optional accessories

Siphon break kit mandatory if generator is below waterline	Wet Exhaust System
Engine electrical system at 24 V	Water Filters
Service/Cruise Kits: fuel and oil filters, raw water pump, impeller, alternator belt,...	Sea water cock
Dry Exhaust system	Welcome Kit

\* Other protections available

\*\* With load from 0 to 100%, speed variation from -2% up to +5%, power factor 0,8 linear and balanced load.

\*\*\* In all directions

For other requirements please contact the Sales Dept.

# SCO 5 Panel



## General Description

Graphic LCD with light Display, 128 x 64 pixels
3 LED indicators
Marine genset measures (see display information)
Marine genset protections (see alarm management)
Running hour indicator
Type B USB for programming
Programming from the same panel
Universal Interface
Preheating function
D+ preexcitation terminal
CAN bus output with SAEJ1939 protocol
2 multipurpose timers
Dimensions 118x 108 x 43 mm
Weight 246 g

## Alarm Management

Shutdown (SD)
High coolant temperature
Low oil pressure
Overspeed
Overload*
Short circuit*
Overcurrent*
Over/Under voltage
Over/Under frequency
Emergency stop
Warnings (WRN)
Over/Under battery voltage
Maintenance request
Sensor Fails (FLS)

## Operating modes

OFF Mode	AUT Mode (auto start/stop engine)
MAN Mode (manual start/stop engine)	

## Power Supply

Voltage supply 12/24 DC with fuse protection
Consumption 60/35 mA

## Operating Conditions

Operating temperature -20+70 °C
Humidity 95 % without condensation
Front Panel Protection IP65
Standard Conformity
EN 61000-6-2, EN 61000-6-4, EN 61010-1
EN 60068-2-6 (2÷25 Hz / ±1,6 mm; 25÷100 Hz / 4.0 g)
EN 60068-2-30:2005 25/55°C, RH 95%, 48hours
EN 60529 (front panel IP65, back side IP20)

## Display Information

Measurement
L1-L3 Voltage (V), Frequency (Hz), Oil Pressure (bar)
Coolant Temperature (°C), Battery voltage (V), RPM
Active Power* (kW), Apparent Power* (kVA), Current* (A), PF*
History log

## Dimensions

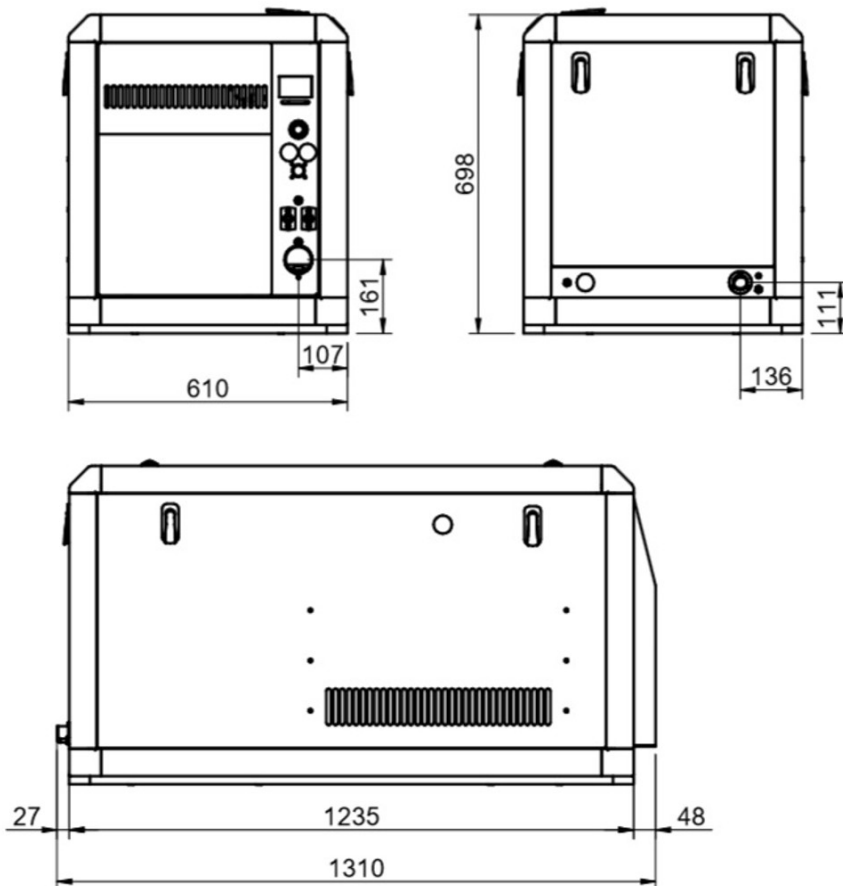
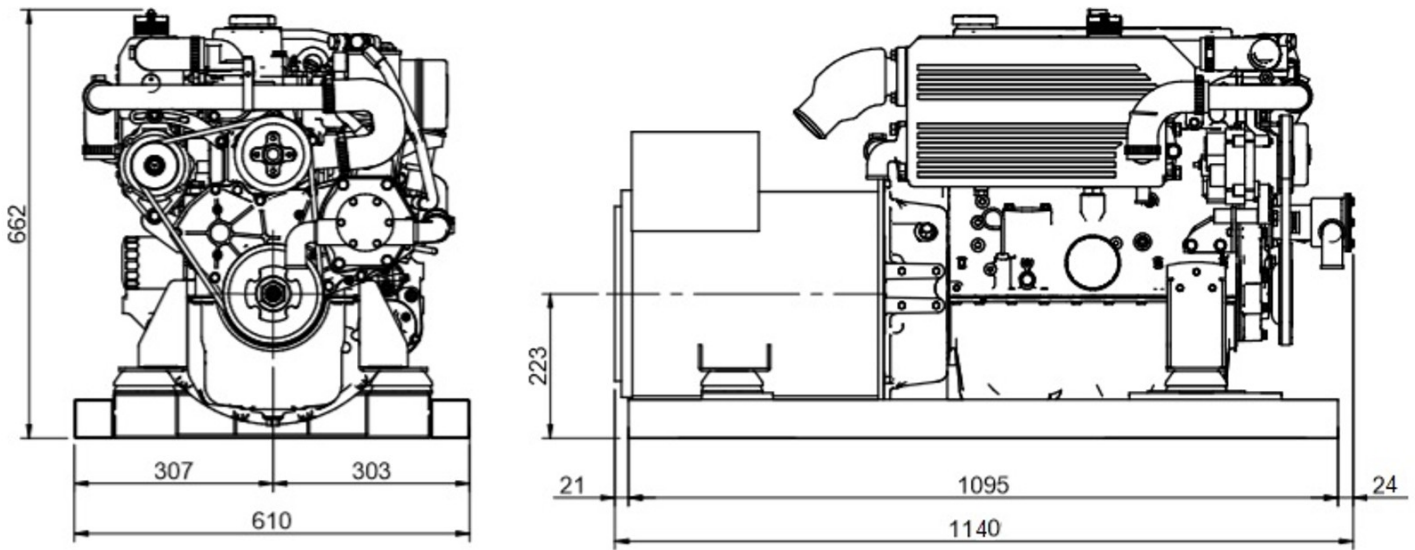

Authorized dealer



Detailed drawings, brochures and manuals are available on the web [soleadvantage.com](http://soleadvantage.com). All rights reserved. Technical specifications, data and presentation are subjected to variations, changes and updates without prior notice. Non-contractual information.

