

MARINE ENGINE

SDZ-280

6 cilindros en línea 272 CV (200 kW) 2300 R. P. M.

Technical specifications

Base engine manufacturer	Deutz
Type	Diesel, 4 stroke
Number of cylinders	6, in line
Intake system	Turbocharged with intercooler
Bore x Stroke	108 mm x 130 mm (4.25 in x 5.12 in)
Total displacement	7146 cc
Compression ratio	17.5:1
Intermittent power _{SN_ (ISO3046/1)}	272 CV (200 kW)
Continuous power	245.0 CV (180 kW)
Max RPM	2300
Injection system	Mechanical and indirect
Starter motor	24 V (4 kW)
Alternator	55 A (24 V)
Maximum operating angle	10 °
Rotation (viewed from flywheel side)	Counterclockwise
Cooling system	Sea water heat exchanger and coolant closed circuit
Dry weight without gearbox	680 Kg (1499.1 lb)
Sea water hose inner diameter	42 mm (1.65 in)
Fuel feeding hose inner diameter	12 mm (0.47 in)
Fuel return hose inner diameter	12 mm (12 in)
Exhaust hose inner diameter	125 mm (4.92 in)
Certifications and emissions	-
Emission compliance	-

Performance curves

Crankshaft torque

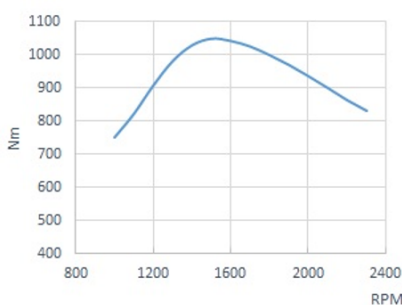

Power (ISO 3046/1)

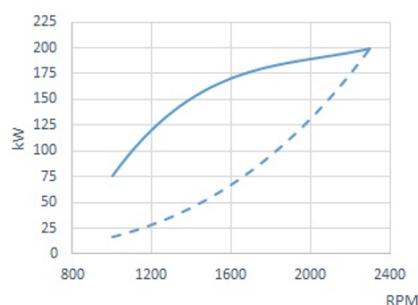

Fuel consumption

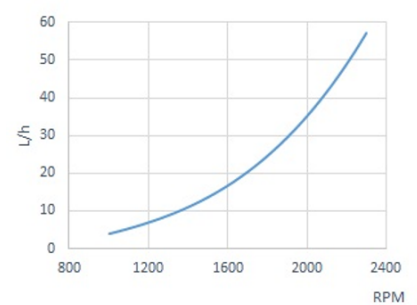

Panel



Dimensions: 255 x 160mm

Panel SSG 30 24V BLANCO Standard

- Revolution counter with multifunction display
- Coolant temperature and oil pressure gauge
- Voltage indicator and battery charge fault
- High coolant temperature alarm
- Low oil pressure alarm
- Preheating indicator
- Front IP65 protection and anti-fog glass
- 5-position key

Accessories

Standard equipment

- Instrument panel SSG 30
- 4 m electrical extension lead
- Oil extraction pump
- Owner's manual and spare parts manual

Optional equipment & kits

- Twin instrument panel installation
- Twin alternator
- Earth isolated electrical system
- Dry exhaust system
- Keel cooling
- Power takeoff shaft or pulley
- Heater inlet
- Drivetrain: propeller, shaft, stern tube
- Water and fuel filters
- Water, exhaust and die

Gearboxes

Model	Type	Output °	Reductions (light Duty)	Reductions (heavy Duty)	Engine weight with gearbox
DMT-100HL	Hydraulic	0°	-	4.07:1-4.50:1-4.95:1-5.29:1	957 Kg (2109 Lbs)
DMT-100IV	Hydraulic	14°	-	2.12:1	842 Kg (1856 Lbs)
TM-1200A	Hydraulic	7°	1.44:1-2.00:1-2.30:1	1.44:1-2.00:1	806 Kg (1778 Lbs)
TM-360	Hydraulic	0°	-	3.50:1-4.00:1-5.00:1	1111 Kg (2449 Lbs)
TM-880A	Hydraulic	10°	-	-	745 Kg (1642 Lbs)

Dimensions

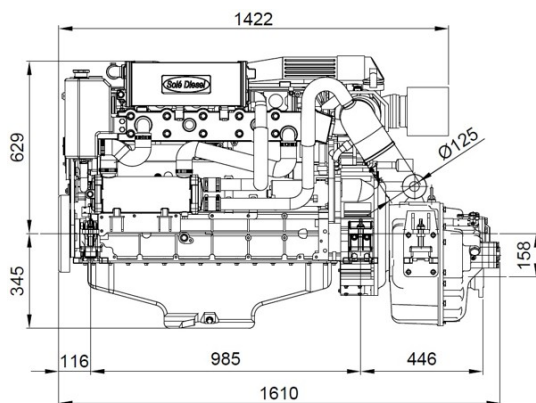

SDZ-280 24V Engine TM-265 2.09:1 Gbox.

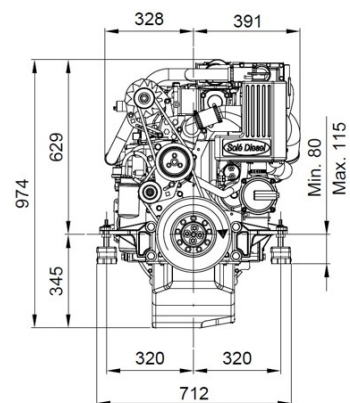

Detailed drawings, brochures and manuals are available on the web soleadvance.com. All rights reserved. Technical specifications, data and presentation are subjected to variations, changes and updates without prior notice. Non-contractual information.



Authorized dealer