

MARINE GENERATORS

7 GS/GSC

Single-Phase

General data

Maximum power*	6.6 kW (6.6 kVA)	Voltage	230 V
Prime Power**	6 kW	Amperage	28.7 A
Frequency	50 Hz	Phases	1

Dimensions and weights

Total length without canopy	757 mm	Total length with canopy	892 mm
Total width without canopy	560 mm	Total width with canopy	560 mm
Total height without canopy	561 mm	Total height with canopy	608 mm
Dry weight without canopy	198 Kg	Dry weight with canopy	220 Kg

Engine

Base engine manufacturer	Mitsubishi	Diameter	76 mm (2.99 in)
Model	MINI-26 GENSET	Stroke	70 mm (2.76 in)
Type	Diesel, 4 stroke	Compression ratio	23:1
Engine RPM	1500	Injection system	Mechanical and indirect
Number of cylinders	3	Intake system	Naturally aspirated
Total displacement	952 cc	SAE Flywheel housing	SAE 5
Oil	SAE 15W40	Coolant capacity	3 L (0.79 gal)
Oil capacity	4 L (1.06 gal)	Flywheel	SAE 6 1/2
Power	7.5 kW (10.2 CV)	Coolant flow rate	24 l/min (6.34 gal/m)
Salt water flow rate	12.3 l/min (3.25 gal/m)	Intake air flow rate	0.64 m ³ /m
Exhaust type	Wet exhaust elbow	V-Belt Protection	Optional

Rating conditions according to ISO 3046 (100 kPa barometric pressure, 30 % relative humidity abd 25 °C (77 ° F))

* Maximum output power: maximum power supplied by the genset at full load

** Prime Power: rated power according to ISO 3046 and ISO 8528-1. 10 % overload capacity one hour in twelve hours.

Fuel system details

1 kW □ 1,36 CV 1 kW □ 1,36 HP (metric) 1 kW □ 1,36 CH

45461 - 6/24

Fuel system details

Consumption 25%	0.8 l/h (0.21 gal)	Fuel type	Diesel
Consumption 50%	1.3 l/h (0.34 gal)	Fuel standards	Fueloil diesel ASTM
Consumption 75%	1.7 l/h (0.45 gal)	Injection pump type	In line
Consumption 100%	2.1 l/h (0.55 gal)	Governor type	Mechanical

Electrical system

Battery voltage	12 V	Stop solenoid type	ETR
Starter motor	1.2 kW	Alternator	40 A
Earth isolated	Optional	IP 65 box kit	Optional
SCO 11 double panel	Optional	Current transformers	Optional

Installation details

Exhaust hose inner diameter	50 mm (1.97 in)	Maximum fuel lift height	0.3 m (0.98 ft)
Sea water hose inner diameter	20 mm (0.79 in)	Maximum raw water lift height	1.3 m (51.18 in)
Fuel feeding hose inner diameter	8 mm (0.31 in)	Maximum sea water temperature	32 ° (89.6 °F)
Fuel return hose inner diameter	6 mm (0.24 in)	Maximum installation angle***	25 °
Minimum battery capacity	12 V 60 Ah		

Alternator details

Brand	Sincro	Cos Phi	1
Model	SK160SZ1	Tropicalized	Yes
Regulator type	BL4	Excitation system	Brushless
Number of poles	4	Voltage regulation accuracy**	1%
Isolation type*	H	Standards	EN 60034-1, IEC 60034-1, ISO 8528-3
IP protection	23	Alternator type	Síncrono

Standard equipment

4 m electrical wiring extension	SCO 5 control panel
Oil extraction pump	Owner's and alternator manual
Rigid bed	Packaging
Silentblocks	

Optional accessories

Siphon break kit mandatory if generator is below waterline	Wet Exhaust System
Engine electrical system at 24 V	Water Filters
Service/Cruise Kits: fuel and oil filters, raw water pump, impeller, alternator belt,...	Sea water cock
Dry Exhaust system	Welcome Kit

* Other protections available

** With load from 0 to 100%, speed variation from -2% up to +5%, power factor 0,8 linear and balanced load.

*** In all directions

For other requirements please contact the Sales Dept.

SCO 5 Panel



General Description

Graphic LCD with light Display, 128 x 64 pixels
3 LED indicators
Marine genset measures (see display information)
Marine genset protections (see alarm management)
Running hour indicator
Type B USB for programming
Programming from the same panel
Universal Interface
Preheating function
D+ preexcitation terminal
CAN bus output with SAEJ1939 protocol
2 multipurpose timers
Dimensions 118x 108 x 43 mm
Weight 246 g

Alarm Management

Shutdown (SD)
High coolant temperature
Low oil pressure
Overspeed
Overload*
Short circuit*
Overcurrent*
Over/Under voltage
Over/Under frequency
Emergency stop
Warnings (WRN)
Over/Under battery voltage
Maintenance request
Sensor Fails (FLS)

Operating modes

OFF Mode	AUT Mode (auto start/stop engine)
MAN Mode (manual start/stop engine)	

Power Supply

Voltage supply 12/24 DC with fuse protection
Consumption 60/35 mA

Operating Conditions

Operating temperature -20+70 °C
Humidity 95 % without condensation
Front Panel Protection IP65
Standard Conformity
EN 61000-6-2, EN 61000-6-4, EN 61010-1
EN 60068-2-6 (2÷25 Hz / ±1,6 mm; 25÷100 Hz / 4.0 g)
EN 60068-2-30:2005 25/55°C, RH 95%, 48hours
EN 60529 (front panel IP65, back side IP20)

Display Information

Measurement
L1-L3 Voltage (V), Frequency (Hz), Oil Pressure (bar)
Coolant Temperature (°C), Battery voltage (V), RPM
Active Power* (kW), Apparent Power* (kVA), Current* (A), PF*
History log

Dimensions

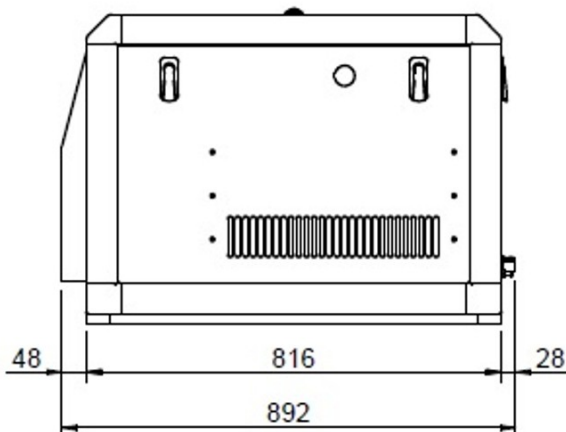
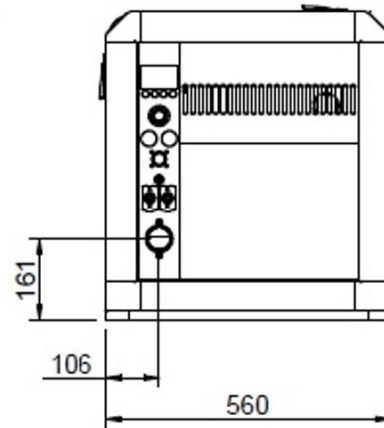
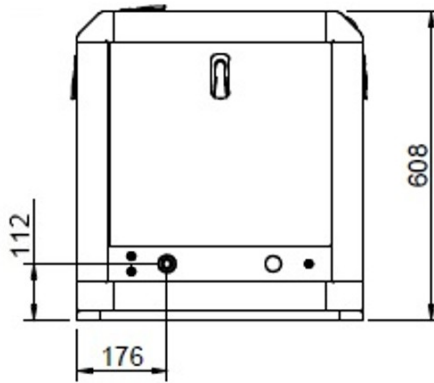
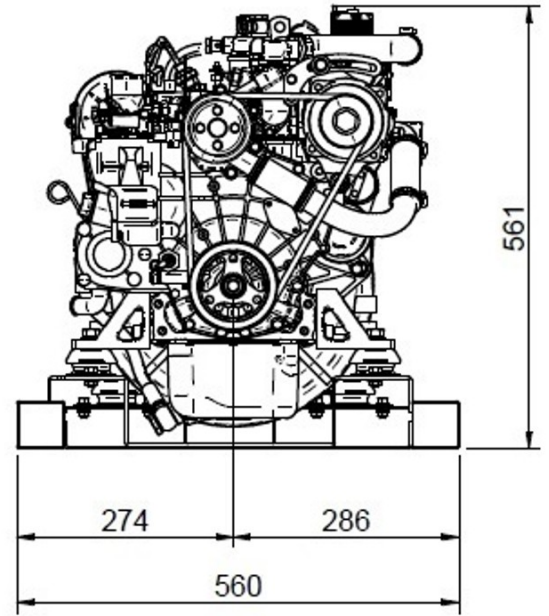
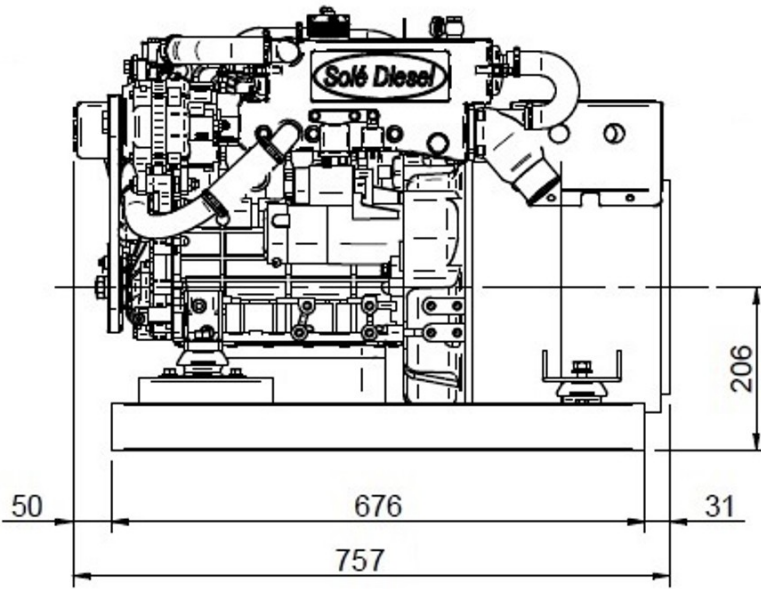

Authorized dealer

