

MARINE GENERATORS

85 GT/GTC

Three-Phase

General data

Maximum power*	68 kW (85 kVA)	Voltage	400/230 V
Prime Power**	61.8 kW	Amperage	122.7 A
Frequency	50 Hz	Phases	3

Dimensions and weights

Total length without canopy	1760 mm	Total length with canopy	2007 mm
Total width without canopy	865 mm	Total width with canopy	865 mm
Total height without canopy	969 mm	Total height with canopy	1048 mm
Dry weight without canopy	988 Kg	Dry weight with canopy	1100 Kg

Engine

Base engine manufacturer	Deutz	Diameter	108 mm (4.25 in)
Model	SDZ-109 GENSET	Stroke	130 mm (5.12 in)
Type	Diesel, 4 stroke	Compression ratio	19:1
Engine RPM	1500	Injection system	Mechanical and direct
Number of cylinders	4	Intake system	Turbocharged
Total displacement	4764 cc	SAE Flywheel housing	SAE 2
Oil	SAE 15W40	Coolant capacity	17.5 L (4.62 gal)
Oil capacity	11 L (2.91 gal)	Flywheel	SAE 11 1/2
Power	81 kW (110.16 CV)	Coolant flow rate	141.5 l/min (37.38 gal/m)
Salt water flow rate	107.4 l/min (28.37 gal/m)	Intake air flow rate	5.5 m3/m
Exhaust type	Wet exhaust elbow	V-Belt Protection	Optional

Rating conditions according to ISO 3046 (100 kPa barometric pressure, 30 % relative humidity abd 25 °C (77 ° F))

* Maximum output power: maximum power supplied by the genset at full load

** Prime Power: rated power according to ISO 3046 and ISO 8528-1. 10 % overload capacity one hour in twelve hours.

Fuel system details

1 kW □ 1,36 CV 1 kW □ 1,36 HP (metric) 1 kW □ 1,36 CH

45461 - 6/24

Fuel system details

Consumption 25%	5.5 l/h (1.45 gal)	Fuel type	Diesel
Consumption 50%	10.2 l/h (2.69 gal)	Fuel standards	Fueloil diesel ASTM
Consumption 75%	15 l/h (3.96 gal)	Injection pump type	Individual
Consumption 100%	19.9 l/h (5.26 gal)	Governor type	Mechanical

Electrical system

Battery voltage	24 V	Stop solenoid type	ETS
Starter motor	4 kW	Alternator	35 A
Earth isolated	Optional	IP 65 box kit	Optional
SCO 11 double panel	Optional	Current transformers	Optional

Installation details

Exhaust hose inner diameter	90 mm (3.54 in)	Maximum fuel lift height	1.3 m (4.27 ft)
Sea water hose inner diameter	42 mm (1.65 in)	Maximum raw water lift height	4 m (157.48 in)
Fuel feeding hose inner diameter	12 mm (0.47 in)	Maximum sea water temperature	32 ° (89.6 °F)
Fuel return hose inner diameter	12 mm (0.47 in)	Maximum installation angle***	10 °
Minimum battery capacity	24 V 90 Ah		

Alternator details

Brand	Meccalte	Cos Phi	0,8
Model	ECP34 1S 4 C	Tropicalized	Yes
Regulator type	DSR	Excitation system	BRUSHLESS
Number of poles	4	Voltage regulation accuracy**	0,01
Isolation type*	H	Standards	EN60034-1, IEC 60034-1
IP protection	23	Alternator type	SÍNCRONO

Standard equipment

4 m electrical wiring extension	SCO 11 control panel
Oil extraction pump	Owner's and alternator manual
Rigid bed	Packaging
Silentblocks	

Optional accessories

Siphon break kit mandatory if generator is below waterline	Water Filters
Service/Cruise Kits: fuel and oil filters, raw water pump, impeller, alternator belt,...	Sea water cock
Dry Exhaust system	Welcome Kit
Wet Exhaust System	Kit Power Take-off

* Other protections available

** With load from 0 to 100%, speed variation from -2% up to +5%, power factor 0,8 linear and balanced load.

*** In all directions

For other requirements please contact the Sales Dept.

SCO 11 Panel



General Description

Graphic LCD with light, 128 x 64 pixels display
Genset measures (see Display Information)
Configuration protected by user and password
Running hour indication
Multilenguaje
Event history log
Genset protections (see Alarm Management)
Preheating function
D+ pre-excitation Terminal
Built-in PLC function
CAN bus information with SAE J1939 protocol
Maintenance hours control
Dimensions 195 x 135 x 47 mm
Board Cutting 172 x 112 mm
Weight 450 g

Alarm Management

Shut Downs (SD)
High coolant temperature
Low oil pressure
Overspeed
Overload*
Short circuit*
Overcurrent*
Over/Under voltage
Over/Under frequency
Emergency stop
Warnings (WRN)
High coolant temperature
Low oil pressure
Over/Under Battery voltage
Maintenance request
Sensor failure detection (FLS)

Operating modes

OFF Mode	AUT Mode (auto start/stop engine)
MAN Mode (manual start/stop engine)	

Power Supply

Voltage supply 12/24 DC with fuse protection
Consumption 80mA (12V) or 51 (24V)

Operating Conditions

Operating temperature -20+70 °C
Humidity 95 % without condensation
Front Panel Protection IP65
Standard Conformity
EN 61000-6-2, EN 61000-6-4, EN 61010-1
EN 60068-2-6 (2÷25 Hz / ±1,6 mm; 25÷100 Hz / 4.0 g)
EN 60068-2-30:2005 25/55°C, RH 95%, 48hours
EN 60529 (front panel IP65, back side IP20)

Display Information

Measurement
L1-L3 Voltage (V), Frequency (Hz), Oil Pressure (bar)
Coolant Temperature (°C), Battery voltage (V), RPM
Active Power* (kW), Apparent Power* (kVA), Current* (A), PF*
History log

Dimensions

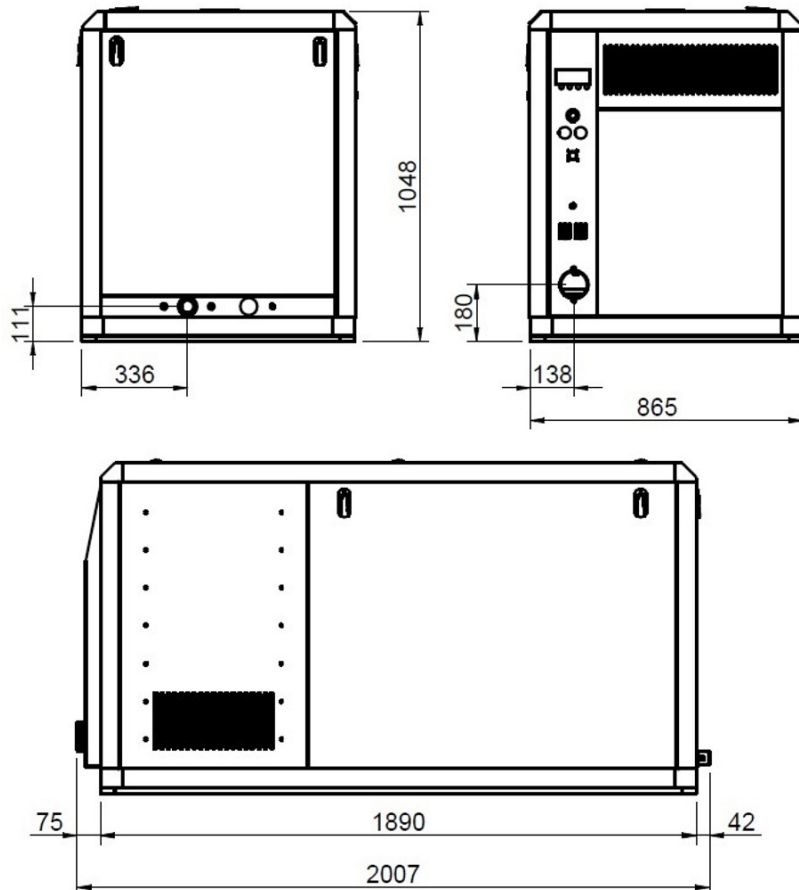
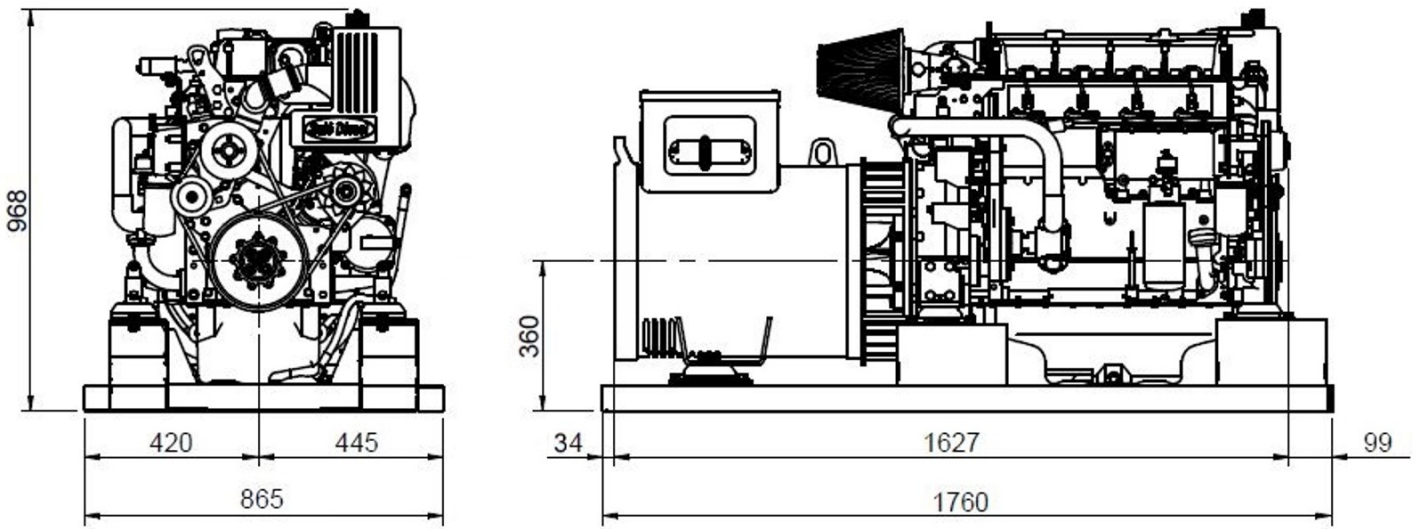

Authorized dealer



Detailed drawings, brochures and manuals are available on the web soleadvantage.com. All rights reserved. Technical specifications, data and presentation are subjected to variations, changes and updates without prior notice. Non-contractual information.

