



MARINE ENGINE

MINI-55

4 cilindros en línea 50.0 CV (36.8 kW) 3000 R. P. M.

Technical specifications

Base engine manufacturer	Mitsubishi
Type	Diesel, 4 stroke
Number of cylinders	4, in line
Intake system	Turbocharged
Bore x Stroke	78 mm x 92 mm (3.07 in x 3.62 in)
Total displacement	1758 cc
Compression ratio	22:1
Intermittent power _{SN_ (ISO3046/1)}	50.0 CV (36.8 kW)
Continuous power	45.0 CV (33.1 kW)
Max RPM	3000
Injection system	Mechanical and indirect
Starter motor	12 V (1.7 kW)
Alternator	120 A (12 V)
Maximum operating angle	15 °
Rotation (viewed from flywheel side)	Counterclockwise
Cooling system	Sea water heat exchanger and coolant closed circuit
Dry weight without gearbox	184 Kg (405.6 lb)
Sea water hose inner diameter	26 mm (1.02 in)
Fuel feeding hose inner diameter	8 mm (0.31 in)
Fuel return hose inner diameter	5 mm (5 in)
Exhaust hose inner diameter	60 mm (2.36 in)
Certifications and emissions	-
Emission compliance	EU: RCD II (DIR. 2013/53/EU)

Performance curves

Crankshaft torque

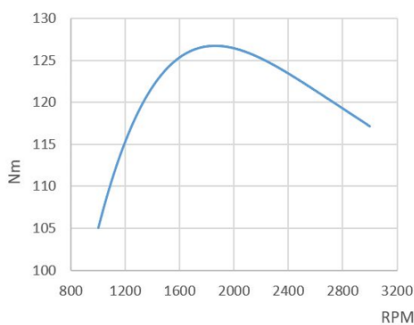

Power (ISO 3046/1)

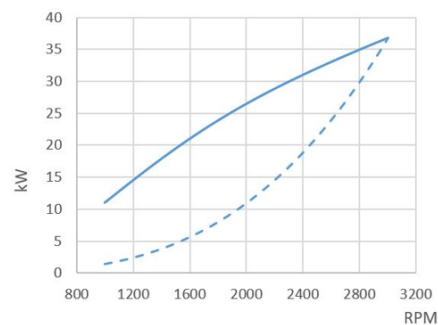

Fuel consumption

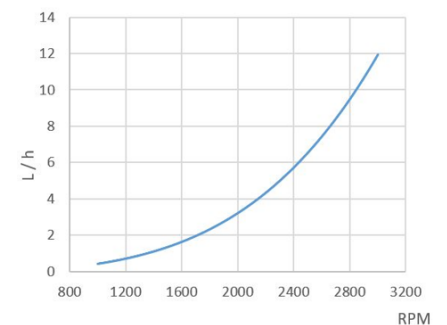

Panel



Dimensions: 180 x 140mm

Panel SSG 20 12V BLANCO Standard

Revolution counter with multifunction display
Coolant temperature and oil pressure indicator
Voltage indicator and battery charge fault
High coolant temperature alarm
Low oil pressure alarm
Preheating indicator
Front IP65 protection and anti-fog glass
5-position key



Dimensions: 255 x 160mm

Panel SSG 30 12V BLANCO Optional

Revolution counter with multifunction display
Coolant temperature and oil pressure gauge
Voltage indicator and battery charge fault
High coolant temperature alarm
Low oil pressure alarm
Preheating indicator
Front IP65 protection and anti-fog glass
5-position key

Accessories

Standard equipment

Instrument panel SSG 20
3 m electrical extension lead
Silentblocks
Oil extraction pump
Owner's manual and spare parts manual

Optional equipment & kits

SSG 30 panel
Twin instrument panel installation
Twin alternator
Earth isolated electrical system
Dry exhaust system
Keel cooling
Power takeoff shaft or pulley
Heater inlet
Drivetrain: propeller, shaft, stern tube
Water and fuel filters
Water, exhaust and diesel fuel hoses

Gearboxes

Model	Type	Output °	Reductions (light Duty)	Reductions (heavy Duty)	Engine weight with gearbox
SP 60	Mechanical	0°	2.15:1	-	230 Kg (507 Lbs)
TM-345	Hydraulic	0°	1.54:1-2.00:1-2.47:1	1.54:1-2.00:1-2.47:1	212 Kg (467 Lbs)
TM-345A	Hydraulic	8°	2.00:1-2.47:1	2.00:1-2.47:1	212 Kg (467 Lbs)
TM-93	Hydraulic	0°	2.09:1-2.40:1-2.77:1	2.09:1-2.40:1-2.77:1	240 Kg (530 Lbs)
TMC-260	Mechanical	0°	2.00:1-2.47:1	2.00:1-2.47:1	205 Kg (451 Lbs)
TMC-60A	Mechanical	7°	2.00:1-2.45:1	-	200 Kg (442 Lbs)
TMC-60P	Mechanical	0°	1.55:1-2.00:1-2.45:1	1.55:1	200 Kg (442 Lbs)
TTMC35P	Mechanical	0°	1.96:1	-	198 Kg (438 Lbs)
ZF 15 MIV	Mechanical	15°	2.13:1	-	207 Kg (456 Lbs)

Dimensions

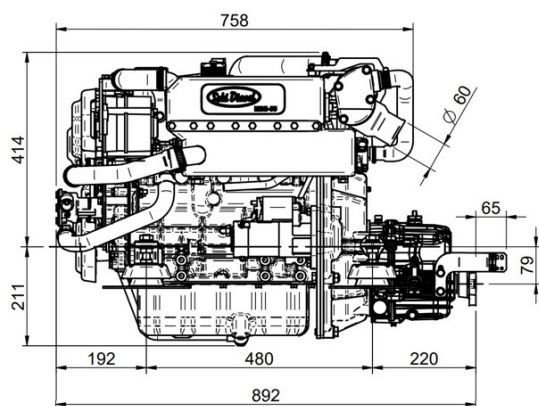

MINI-55 v6 Engine TMC-60P 2.00:1 Gbox.

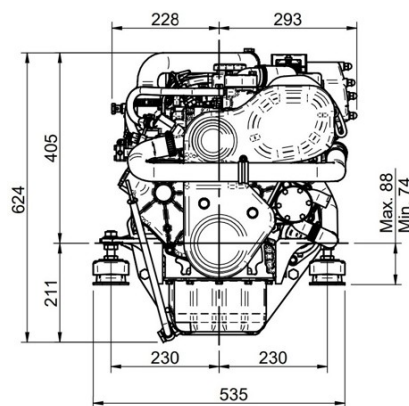

Detailed drawings, brochures and manuals are available on the web soleadance.com. All rights reserved. Technical specifications, data and presentation are subjected to variations, changes and updates without prior notice. Non-contractual information.



Authorized dealer